

INDUCTION HOB

VI23212.

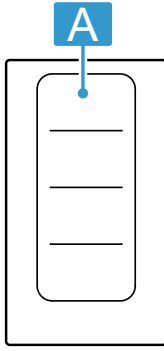



A	g^1	b^1
	2.200 W	3.700 W
	3.300 W	3.700 W

¹ IEC 60335-2-6

You can find additional information and explanations online.
Scan the QR code on the title page.



Table of contents

INFORMATION FOR USE	
1 Safety	3
2 Avoiding material damage	5
3 Environmental protection and saving energy	5
4 Suitable cookware	6
5 Disposal	6
6 Familiarising yourself with your appliance	7
7 Before using for the first time	8
8 Basic operation	8
9 Flex Zone	9
10 Booster for pots	10
11 Frying sensor function	11
12 Automatic switch-off	13
13 Cleaning and servicing	13
14 FAQs	14
15 Troubleshooting	15
16 Customer Service	16
17 INSTALLATION INSTRUCTIONS	17
17.3 General information	17

1 Safety

Observe the following safety instructions.

1.1 General information

- Read this instruction manual carefully.
- Keep the instructions, the appliance and the product information safe for future reference or for the next owner.
- Do not connect the appliance if it has been damaged in transit.

1.2 Intended use

Only a licensed professional may connect appliances without plugs. Damage caused by incorrect connection is not covered under the warranty.

The appliance can only be used safely if it is correctly installed according to the safety instructions. The installer is responsible for ensuring that the appliance works perfectly at its installation location.

Only use this appliance:

- To prepare meals and drinks.
- Under supervision. Never leave the appliance unattended when cooking for short periods.
- in private households and in enclosed spaces in a domestic environment.
- Up to an altitude of 4000 m above sea level.

Do not use the appliance:

- With an external timer or a separate remote control. This does not apply if operation with appliances included in EN 50615 is switched off.

If you wear an active implantable medical device (e.g. a pacemaker or defibrillator), check with your doctor that it complies with Council Directive 90/385/EEC of 20th June 1990, EN 45502-2-1 and EN 45502-2-2, and that it has been chosen, implanted and programmed in accordance with VDE-AR-E 2750-10. If these conditions are satisfied, and if, in addition, non-metal cooking utensils and cookware with non-metal handles are used, it is safe to use this induction hob as intended.

1.3 Restriction on user group

This appliance may be used by children aged 8 or over and by people who have reduced physical, sensory or mental abilities or inadequate experience and/or knowledge, provided that they are supervised or have been instructed on how to use the appliance safely and have understood the resulting dangers.

Do not let children play with the appliance. Children must not perform cleaning or user maintenance unless they are at least 15 years old and are being supervised.

Keep children under the age of 8 years away from the appliance and power cable.

1.4 Safe use

⚠ WARNING – Risk of fire!

Leaving fat or oil cooking on an unattended hob can be dangerous and may lead to fires.

- ▶ Never leave hot oil or fat unattended.
- ▶ Never attempt to extinguish a fire using water; instead, switch off the appliance and then cover with a lid or a fire blanket.

The cooking surface becomes very hot.

- ▶ Never place flammable objects on the cooking surface or in its immediate vicinity.
- ▶ Never place objects on the cooking surface.

The appliance will become hot.

- ▶ Do not keep combustible objects or aerosol cans in drawers directly underneath the hob.

Hob covers can cause accidents, for example due to overheating, catching fire or materials shattering.

- ▶ Do not use hob covers.

After every use, switch off the hob using the main switch.

- ▶ Do not wait until the hob turns off automatically as there are no longer any pots and pans on it.

Food may catch fire.

- ▶ The cooking process must be monitored. A short process must be monitored continuously.

⚠ WARNING – Risk of burns!

The appliance and its parts that can be touched become hot during use, particularly the hob surround, if fitted.

- ▶ Caution should be exercised here in order to avoid touching heating elements.
- ▶ Young children under 8 years of age must be kept away from the appliance.

Hob guards may cause accidents.

- ▶ Never use hob guards.

The appliance becomes hot during operation.

- ▶ Allow the appliance to cool down before cleaning.

Metal objects on the hob quickly become very hot.

- ▶ Never place metal objects (such as knives, forks, spoons and lids) on the hob.

⚠ WARNING – Risk of electric shock!

Improper repairs are dangerous.

- ▶ Repairs to the appliance should only be carried out by trained specialist staff.

- ▶ Only use genuine spare parts when repairing the appliance.
- ▶ If the power cord or the appliance power cable of this appliance is damaged, it must be replaced with a special power cord or special appliance power cable, which is available from the manufacturer or its Customer Service.

- ▶ If the power cord of this appliance is damaged, it must be replaced by trained specialist staff.

If the appliance or the power cord is damaged, this is dangerous.

- ▶ Never operate a damaged appliance.
- ▶ If the surface is cracked, you must switch off the appliance in order to prevent a possible electrical shock. To do this, switch off the appliance via the fuse in the fuse box rather than at the main switch.

- ▶ Call customer service. → *Page 16*

An ingress of moisture can cause an electric shock.

- ▶ Do not use steam- or high-pressure cleaners to clean the appliance.

The insulation on cables of electrical appliances may melt if it touches hot parts of the appliance.

- ▶ Never bring electrical appliance cables into contact with hot parts of the appliance.

If metallic objects come into contact with the fan that is located on the underside of the hob, this may cause an electric shock.

- ▶ Do not store long, pointed metallic objects in the drawers below the hob.

⚠ WARNING – Risk of injury!

Saucepans may suddenly jump due to liquid between the saucepan base and the hotplate.

- ▶ Always keep hotplates and saucepan bases dry.
- ▶ Never use icy-cold cookware that has been in the freezer.

When cooking in a bain marie, the hob and cooking container could shatter due to overheating.

- ▶ The cooking container in the bain marie must not directly touch the bottom of the water-filled pot.
- ▶ Only use heat-resistant cookware.

An appliance with a cracked or broken surface can cause cuts.

- ▶ Do not use the appliance if it has a cracked or broken surface.

⚠ WARNING – Risk of suffocation!

Children may put packaging material over their heads or wrap themselves up in it and suffocate.

- ▶ Keep packaging material away from children.

- ▶ Do not let children play with packaging material.

Children may breathe in or swallow small parts, causing them to suffocate.

- ▶ Keep small parts away from children.
- ▶ Do not let children play with small parts.

2 Avoiding material damage

This is where you can find the most common causes of damage and tips on how to avoid them.

Damage	Cause	Measure
Stains	Unsupervised cooking process.	Monitor the cooking process.
Stains, blisters	Spilled food, especially food with a high sugar content.	Remove immediately with a glass scraper.
Stains, blisters or fractures in the glass	Defective cookware, cookware with melted enamel or cookware with copper or aluminium base.	Use suitable cookware that is in a good condition.
Stains, discolouration	Unsuitable cleaning methods.	Only use cleaning agents that are suitable for glass ceramic, and only clean the hob when it is cold.
Blisters or fractures in the glass	Knocks or falling cookware, cooking accessories or other hard or pointed objects.	When cooking, do not hit the glass or let objects fall onto the hob.
Scratches, discolouration	Rough cookware bases or moving the cookware on the hob.	Check the cookware. Lift the cookware when moving it.
Scratches	Salt, sugar or sand.	Do not use the hob as a work surface or storage space.
Damage to the appliance	Cooking with frozen cookware.	Never use frozen cookware.
Damage to the cookware or the appliance	Cooking without contents.	Never place or heat empty cookware on a hot cooking zone.
Glass damage	Melted material on the hot cooking zone or hot pot lid on the glass.	Do not place greaseproof paper or aluminium foil nor plastic containers or pot lids on the hob.
Overheating	Hot cookware on the control panel or on the frame.	Never place hot cookware on these areas.

ATTENTION

A fan is located on the underside of this hob.

- ▶ If a drawer is located on the underside of the hob, do not store any small or pointed objects, paper or tea

towels in it. These objects may be sucked in and damage the fan or impair the cooling.

- ▶ There must be a clearance of at least 2 cm between the contents of the drawer and the fan entry point.

3 Environmental protection and saving energy

3.1 Disposing of packaging

The packaging materials are environmentally compatible and can be recycled.

- ▶ Sort the individual components by type and dispose of them separately.

3.2 Saving energy

If you follow these instructions, your appliance will use less energy.

Select the cooking zone to match the size of your pan. Centre the cookware on the hob.

Use cookware whose base diameter is the same diameter as the hotplate.

Tip: Cookware manufacturers often give the upper diameter of the saucepan. It is often larger than the base diameter.

- ✓ Unsuitable cookware or incompletely covered cooking zones consume a lot of energy.

Cover saucepans with suitable lids.

- ✓ Cooking without a lid consumes considerably more energy.

Lift lids as infrequently as possible.

- ✓ When you lift the lid, a lot of energy escapes.

Using a glass lid

- ✓ You can see into the pan through a glass lid without having to lift it.

Use pots and pans with flat bases.

- ✓ Uneven bases increase energy consumption.

Use cookware that is suitable for the quantity of food.

- ✓ Large items of cookware containing little food need more energy to heat up.

Cook with only a little water.

- ✓ The more water there is in the cookware, the more energy that is required to heat it up.

Turn down to a lower power level early on.

- ✓ If you use an ongoing power level that is too high, you will waste energy.



4 Suitable cookware

Cookware that is suitable for induction cooking must have a ferromagnetic base, i.e. it must be attracted by a magnet. The base must also match the size of the cook-

ing zone. If cookware is not detected on a cooking zone, place this on the cooking zone with the next smallest diameter.

4.1 Size and characteristics of the cookware

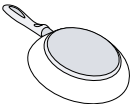
To be able correctly detect the cookware, you must take the size and the material of the cookware into consideration. All cookware bases must be perfectly flat and smooth.

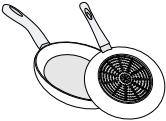
Cookware	Materials	Properties
Recommended cookware 	Stainless steel cookware in a sandwich design that distributes the heat well.	This cookware distributes the heat evenly, heats up quickly, and ensures that it can be detected easily.
Suitable  	Ferromagnetic cookware made of enamelled steel, cast iron or special induction cookware made of stainless steel.	This cookware distributes the heat evenly, heats up quickly, and ensures that it can be detected.
	The base is not fully ferromagnetic.	If the ferromagnetic area is smaller than the base of the cookware, only the area that is ferromagnetic heats up. As a result, the heat is not distributed evenly.
Not suitable	Cookware bases that contain aluminium.	These cookware bases reduce the ferromagnetic area, which means that less power is emitted to the cookware. This cookware may not be sufficiently detected or may not be detected at all, and therefore does not heat sufficiently.
	Cookware made from normal thin steel, glass, clay, copper or aluminium.	

Notes

- Do not use adapter plates between the hob and the cookware.
- Do not heat up empty cookware and do not use cookware with a thin base, as this may become very hot.

5 Disposal

5.1 Disposing of old appliance

Valuable raw materials can be reused by recycling.

- ▶ Dispose of the appliance in an environmentally friendly manner. Information about current disposal methods are available from your specialist dealer or local authority.



This appliance is labelled in accordance with European Directive 2012/19/EU concerning used electrical and electronic appliances (waste electrical and electronic equipment - WEEE). The guideline determines the framework for the return and recycling of used appliances as applicable throughout the EU.

6 Familiarising yourself with your appliance

6.1 Cooking with induction

In comparison to conventional hobs, induction technology brings with it a series of changes and has a num-

ber of benefits such as time savings when cooking and frying, energy savings as well as greater ease of cleaning and care. It also offers improved heat control as the heat is generated directly in the cookware.

6.2 Control panel

You can use the control panel to configure some functions of your appliance and to obtain information about the operating status.

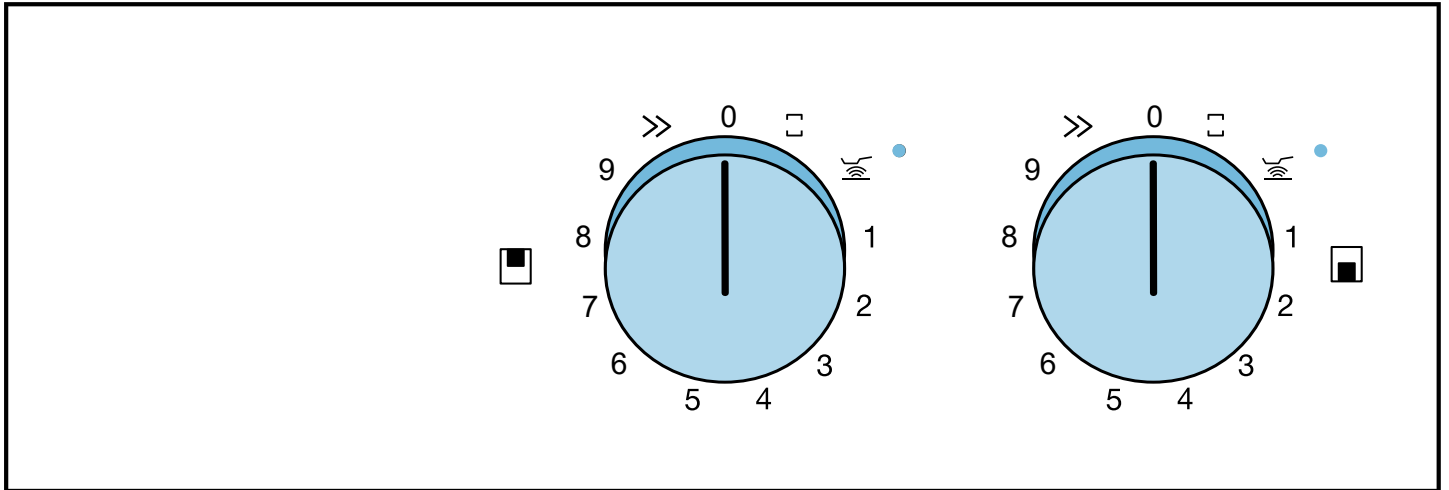

Control knob

You can use the control knobs to set the power levels and other functions of your appliance and to obtain information about the operating status.

You can turn the control knobs clockwise or anti-clockwise, starting from position 0.

The markings on the control knob show the assignment to each cooking zone and the setting from power level 1 to 9, the powerBoost function and the flex function.

	Front cooking zone
	Rear cooking zone
0	Switching off the cooking zone
	Activating the flex function
	Switching on the frying sensor
1-9	Setting the power level
1-5	Setting the temperature settings
>>	Activating the PowerBoost function

Indicator

The indicator lights up when the frying sensor is switched on.

	Frying sensor
--	---------------

Indicators on the illuminated rings

Each control knob is encircled by an illuminated ring with various display functions.

The illuminated ring on the control knob has an visual indicator for each function. The illuminated ring changes colour when you activate particular functions or processes.

Cooking zone

Before you start cooking, check whether the size of the cookware fits the cooking zone that you want to use for cooking.

Area	Cooking zone type
	Single cooking zone
	Flexible cooking zone → "Flex Zone", Page 9

6.3 Residual heat indicator

The hob has a residual heat indicator for each cooking zone. The illuminated ring on the control knob continues to flash orange until the cooking zone cools down. Do not touch the cooking zone when the illuminated ring on the control knob is flashing orange or immediately after the illuminated ring on the control knob goes out.

If you remove the cookware from the cooking zone during cooking, the illuminated ring on the control knob flashes orange.

If you switch off the cooking zone, the illuminated ring on the control knob flashes. Even if the hob has been switched off, the illuminated ring on the control knob continues flashing orange until the cooking zone has cooled down.

7 Before using for the first time

Observe the following recommendations.

7.1 Initial cleaning

Remove any leftover packaging from the hob surface and wipe the surface with a damp cloth. You can find a list of recommended detergents on the official website www.gaggenau.com.

More information on care and cleaning. → *Page 13*

7.2 Cooking with induction

In comparison to conventional hobs, induction technology brings with it a series of changes and has a number of benefits such as time savings when cooking and frying, energy savings as well as greater ease of cleaning and care. It also offers improved heat control as the heat is generated directly in the cookware.

7.3 Cookware

You can find a list of recommended cookware on the official website www.gaggenau.com.

Further information on suitable cookware. → *Page 6*

8 Basic operation

8.1 Switching on the hob

1. Use the control knob to select the cooking zone.
2. Push in the control knob and turn it to the required power level.

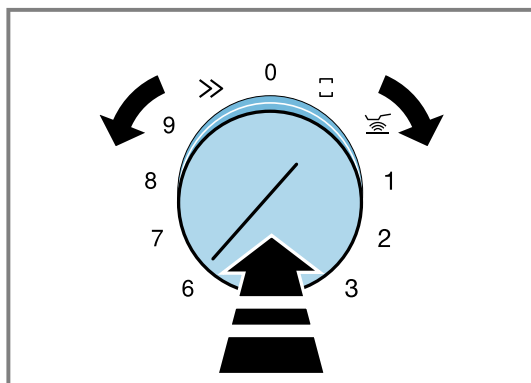

- ✓ The illuminated ring on the control knob lights up orange.
 - ✓ The power level has been set.
3. If there is no cookware on the cooking zone or the appliance does not detect the cookware, turn the control knob back to 0.
- ✓ The illuminated ring on the control knob stops flashing.

Notes

- In order to protect the appliance's electronic parts from overheating or surge currents, the hob may temporarily reduce the power level.
- In order to prevent the appliance from producing excess noise, the hob may temporarily reduce the power level.
- If there is no cookware on the cooking zone or the appliance does not detect the cookware, the illuminated ring on the control knob lights up white. After approx. 9 minutes, the appliance switches the cooking zone off. The illuminated ring on the control knob

flashes orange and white. Turn the control knob back to 0. The illuminated ring on the control knob stops flashing.

8.2 Switching off the hob

- ▶ Turn the control knob to 0.
- ✓ The residual heat indicator lights up and the illuminated ring on the control knob flashes orange until the cooking zone has cooled down.

Note: Always remove cookware, saucepan lids or other metal objects from the hob after cooking. If you accidentally switch on one of the cooking zones when cleaning the worktop or touching a control knob, these kinds of objects will heat up very quickly.

8.3 Cooking tips

- When heating up puree, cream soups or thick sauces, stir occasionally.
- To preheat, set the power level 8-9.
- When cooking with the lid on, reduce the power level as soon as you see steam escaping. The cooking result is not affected by the steam escaping.
- After cooking, place a lid on the cookware until you serve the dish.
- To cook with the pressure cooker, observe the manufacturer's instructions.
- Do not cook food for too long, otherwise nutrients will be lost.
- Ensure that the oil does not smoke.
- To brown the food, fry it in small portions, one after the other.
- Some items of cookware may reach high temperatures while the food is cooking. You should therefore use oven gloves.
- You can find recommendations for energy-efficient cooking under → *"Saving energy", Page 5*

Cooking recommendations

The overview shows which power level is suitable for which food. The cooking time may vary depending on the type, weight, thickness and quality of the food.

Power level	Cooking methods	Examples
8-9	Pre-heating Searing Heating Bringing to a quick boil Blanching	Water Meat Fat or oil, liquids Soups, sauces Vegetables
6-8	Frying	Meat, potatoes
5-7	Frying	Fish
6-7	Frying Cooking with the lid off	Pastries or egg dishes, e.g. pancakes Pasta, liquids
4-5	Ongoing cooking with the lid off	Potato dumplings, vegetable soups, stews, poached eggs
3-4	Ongoing cooking with the lid off	Scalded sausages
4-5	Steaming Stewing Braising	Vegetables, potatoes, fish Vegetables, fruit, fish Roulades, meat rolls, vegetables
2-4	Braising	Goulash
2-4	Cooking with the lid on	Soups, sauces
2-3	Defrosting Cooking with the lid on Thickening	Frozen products Rice, pulses, vegetables Egg dishes, e.g. omelette
1-2	Heating or keeping warm	Soups, vegetables in sauce
1	Heating or keeping warm Melting	Stews, e.g. lentil stew Butter, chocolate

9 Flex Zone

You can use the Flex cooking zone as a single cooking zone or as two independent cooking zones. The Flex cooking zone consists of four inductors. The inductors work independently of each other and only activate area of the hob that is covered by the cookware.

9.1 Cookware positions for a single cooking zone

This is where you can find an overview of the positioning of the cookware. In order to guarantee good pot detection and heat distribution, position the cookware in the centre.

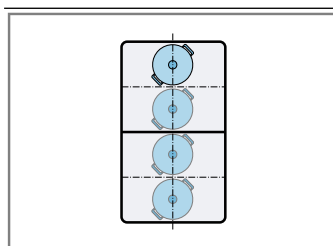

For a diameter of up to 13 cm, position the cookware on one of the four positions as shown in the illustration.

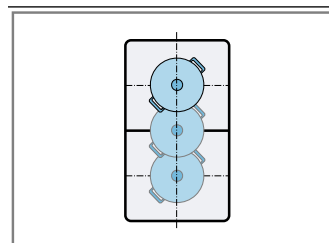

For a diameter over 13 cm, position the cookware on one of the three positions as shown in the illustration.

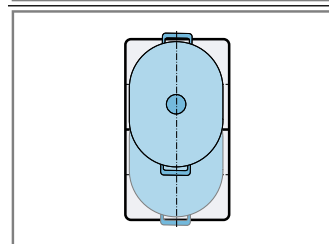

If the cookware covers more than one cooking zone, position the cookware starting on the upper or lower edge of the flexible cooking zone.

9.2 Cookware positions for two independent cooking zones

This is where you can find an overview of the positioning of the cookware. You can use the front and rear cooking zones with two inductors each independently of each other. Set the required power level for each individual cooking zone.

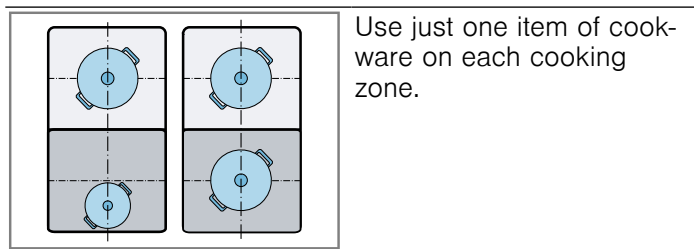

9.3 Using the Flex cooking zone as a single cooking zone

Requirement: The cooking zones are connected.

→ "Connecting the two cooking zones", Page 10

- ▶ Use the entire cooking zone.

Connecting the two cooking zones

1. Set down the cookware.
 2. Turn one of the control knobs one notch anti-clockwise to 0.
 3. Select the power level with the other control knob.
- ✓ The illuminated rings on both control knobs light up orange.
 - ✓ The Flex cooking zone is activated.

Changing the power level

- ▶ Use the control knob that is not turned to 0 to change the power level.

Adding new cookware

1. Set down the new cookware.
 2. Turn the control knob that is currently turned to 0 one notch anti-clockwise to 0 and then one notch clockwise to 0.
- ✓ The hob detects the new cookware and the heat setting that was previously selected is retained.

Note: If you move or lift the item of cookware onto the active cooking zone, the cooking zone automatically starts searching and the power level you selected previously is retained.

Separating the cooking zones

- ▶ Turn the control knob currently turned to 0 one notch anti-clockwise to 0.
- ✓ The Flex cooking zone is deactivated.
- ✓ The two cooking zones operate as two independent cooking zones.

Note: If you switch off the hob and switch it back on again, the flexible cooking zone is switched back to two independent cooking zones.

9.4 Using the Flex cooking zone as two independent cooking zones

- ▶ Use the Flex cooking zone as two independent cooking zones.
→ "Basic operation", Page 8

10 Booster for pots

You can use the Booster for pots function to heat up large volumes of water more quickly than with power level 9.

This function is available for a cooking zone, provided the other cooking zone is not in use.

Otherwise, the illuminated ring flashes three times and 3 signal tones sound. Then power level 9 will be set automatically without activating the function.

Note: For the FlexZone, you can activate the function even if you use this as a single cooking zone.

10.1 Switching on Booster for pots

Requirements

- Only one cooking zone is activated.
- The control knob for the other cooking zone is turned to 0.

- ▶ Push in the control knob and turn it one notch anti-clockwise to 0.

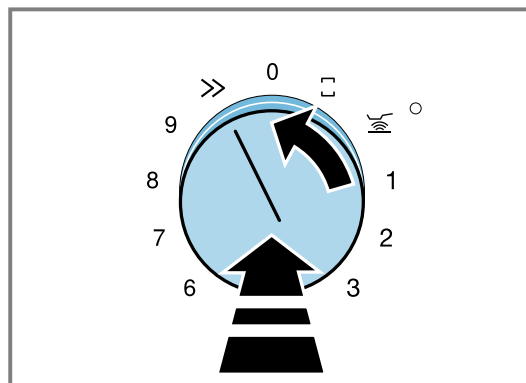

- ✓ A signal tone sounds.
- ✓ The illuminated ring on the control knob goes out and then lights up orange.
- ✓ The function is activated.

10.2 Switching off Booster for pots

- ▶ Push in the control knob and turn it to the required power level.
- ✓ A signal tone sounds.
- ✓ The illuminated ring on the control knob goes out and then lights up orange.
- ✓ The function is deactivated.

Note: In certain circumstances, the Booster for pots function automatically switches off in order to protect the electronic elements inside the hob. In this case, the ap-

pliance automatically sets power level 9. The illuminated ring on the control knob flashes three times and three signal tones sound.

→ "Deactivating Booster for pots after the safety shut-off", Page 11

11 Frying sensor function

If you are frying food, use this function to maintain the suitable pan temperature. The cooking zones that have this function are identified by the roasting sensor function symbol.

11.1 Advantages when frying

- The cooking zone only continues heating for as long as this is necessary to maintain the temperature. This saves energy and prevents the oil or fat from overheating.
- The frying sensor function reports when the empty frying pan has reached the optimum temperature for adding oil and then for adding the food.

11.2 Temperature levels

Levels		Suitable for
1	Very low	Preparing and reducing sauces, stewing vegetables and frying food in extra virgin olive oil, butter or margarine.
2	Low	Frying food in extra virgin olive oil, butter or margarine, e.g. omelettes.
3	Low - Medium	Frying fish and thick food such as meatballs and sausages.
4	Medium - High	Frying steaks (medium or well done), breaded frozen products, and thin food such as schnitzel, strips of meat and vegetables.

11.4 Recommendations for cooking with the frying sensor

The overview shows which temperature level ™ is suitable for which food. The frying time ☉ min may vary depending on the type, weight, thickness and quality of the food.

The set temperature level varies depending on the pan that is used. Preheat the empty pan. Add oil and the food after the signal tone sounds.

	™	☉ min
Meat		
Escalope, plain	4	6-10
Escalope, breaded	4	6-10
Fillet	4	6-10
Chops ¹	3	10-15
Cordon bleu ¹	4	10-15

10.3 Deactivating Booster for pots after the safety shut-off

Requirements

- The illuminated ring on the control knob flashes three times and three signal tones sound.
- The appliance has automatically set power level 9.
- ▶ Turn the control knob one notch clockwise to 0 or turn it to the required power level.

Notes

- Do not place a lid on the pan. Otherwise, the function is not activated correctly. Use a splatter guard to prevent fat from spitting out.
- Use oil or fat that is suitable for stir fries. If you are using butter, margarine, cold-pressed olive oil or lard, use temperature setting 1 or 2.
- Never leave a frying pan unattended during heating, regardless of whether or not it contains food.
- If the cooking zone is a higher temperature than the cookware or vice versa, the frying sensor is not activated correctly.

Levels		Suitable for
5	High	Frying food at high temperatures, e.g. rare steaks, potato fritters and fried potatoes.

11.3 Recommended cookware

Special cookware has been developed for this function, which delivers the best results.

The recommended cookware is available from customer service, specialist retailers or our online shop www.gaggenau.com.

Note: You can also use other cookware. Depending on the composition of the cookware, the achieved temperature may differ from the selected temperature level.

	™	☉ min
Steak, rare, 3 cm thick	5	6-8
Steak, medium, 3 cm thick	4	8-12
Steak, well done, 3 cm thick	4	8-12
Poultry breast, 2 cm thick ¹	3	10-20
Sausages, pre-boiled or raw ¹	3	8-20
Hamburgers, rissoles ¹	3	6-30

¹ Turn frequently.

	⌘	⌚ min
Strips of meat, gyros	4	7-12
Minced meat	4	6-10
Bacon	2	5-8
Fish		
Fish, fried, e.g. trout	3	10-20
Fish fillet, plain	3-4	10-20
Fish fillet, breaded	3-4	10-20
Scampi	4	4-8
Prawns	4	4-8
Egg dishes		
Pancakes ¹	5	1.5-2.5
Omelette ¹	2	3-6
Fried eggs	2-4	2-6
Scrambled eggs	2	4-9
Shredded pancakes	3	10-15
French toast ¹	3	4-8
Potatoes		
Fried potatoes, boiled in their skin	5	6-12
Fried potatoes, from raw potatoes	4	15-25
Potato pancakes ¹	5	2.5-3.5
Swiss rösti	2	50-55
Glazed potatoes	3	15-20
Vegetables		
Garlic, onions	1-2	2-10
Courgettes, aubergines	3	4-12
Peppers, green asparagus	3	4-15
Braising vegetables (fried in fat but with no water added), e.g. courgettes, green peppers	1	10-20
Mushrooms	4	10-15
Glazed vegetables	3	6-10
Fried onions	3	5-10
Frozen products		
Escalope	4	15-20
Cordon bleu ²	4	10-30
Poultry breast ²	4	10-30
Chicken nuggets	4	10-15
Gyros	4	10-15
Kebab	4	10-15
Fish fillet, plain	3	10-20
Fish fillet, breaded	3	10-20
Fish fingers	4	8-12
Chips	5	4-6
Stir-fried meals, e.g. fried vegetables with chicken	3	6-10
Spring rolls	4	10-30

¹ Cooking time per serving. Fry one portion after the other.
² Turn frequently.

	⌘	⌚ min
Camembert/cheese	3	10-15
Sauces		
Tomato sauce with vegetables	1	25-35
Béchamel sauce	1	10-20
Cheese sauce, e.g. Gorgonzola sauce	1	10-20
Reduced sauces, e.g. tomato sauce, Bolognese sauce	1	25-35
Sweet sauces, e.g. orange sauce	1	15-25
Other		
Camembert/cheese	3	7-10
Dried instant meals to which water is added, e.g. pasta dishes	1	5-10
Croutons	3	6-10
Almonds/walnuts/pine nuts	4	3-15

11.5 Switching on the Frying Sensor

- Place the cookware in the centre of the cooking zone.
 - Ensure that the diameter of the cookware base matches the size of the hotplate.
- Push in the control knob and turn it two notches clockwise to .

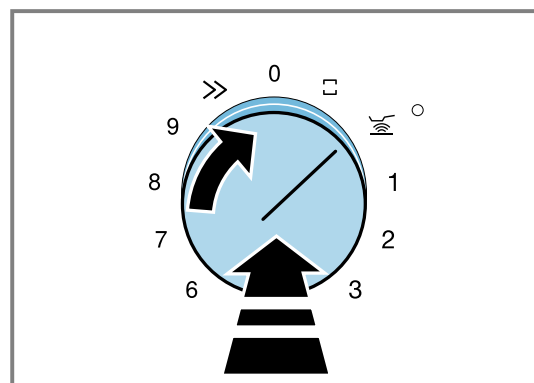

- ✓ The illuminated ring on the control knob lights up white.
- ✓ After 3 seconds, a signal sounds and the indicator next to  lights up.

3. Use the control knob to select the required temperature level.
→ "Recommendations for cooking with the frying sensor", Page 11

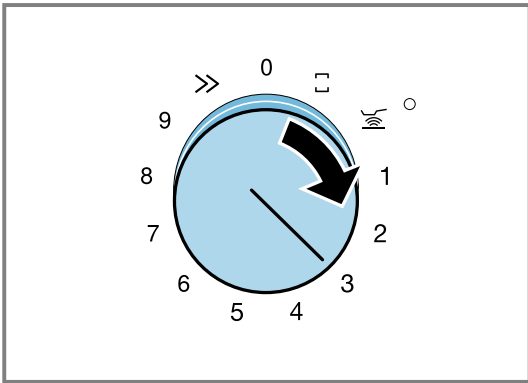

For this function, the temperature levels 1 to 5 are available.

→ "Temperature levels", Page 11

If a temperature level above 5 is selected, the illuminated ring on the control knob flashes orange and white and the appliance does not activate the function.

- ✓ The function is activated.
 - ✓ The illuminated ring on the control knob dims from white to orange while the appliance is heating up.
 - ✓ A signal tone sounds once the set temperature is reached.
4. Once the frying temperature has been reached, add the oil and then the food to the pan.
5. Turn the food so that it does not burn.

11.6 Switching off Frying Sensor

- ▶ Turn the control knob that you used to select the temperature to 0.
- ✓ The cooking zone is switched off.
- ✓ The residual heat indicator lights up.

12 Automatic switch-off

If you operate a cooking zone for an extended period and do not change any settings, the automatic safety shut-off is activated. Depending on which performance level has been selected, the cooking zone switches off automatically after 1 to 10 hours.

A signal tone indicates that the time has elapsed. The illuminated ring on the control knob flashes orange and white. The cooking zone stops heating.

12.1 Switch-on time depending on the power levels

The following overview displays the number of hours after which the hob is switched off, depending on the selected power level.

Power level	Time
1	10 hours
2-3	5 hours
4-5	4 hours
6-7	3 hours
8-9	1 hour

If you activate the frying sensor, the hob switches off at power levels 1 to 5 after 3 hours.

12.2 Switching the appliance back on after automatic switch-off

1. Turn the control knob to 0.
2. Turn the control knob for the required cooking zone to the power level.

13 Cleaning and servicing

To keep your appliance working efficiently for a long time, it is important to clean and maintain it carefully.

13.1 Cleaning products

You can obtain suitable cleaning products and glass scrapers from customer service, the online shop or a retailer.

ATTENTION

Unsuitable cleaning products may damage the surfaces of the appliance.

- ▶ Never use unsuitable cleaning products.
- ▶ Do not use cleaning products while the hob is still hot. This may cause marks on the surface.

Unsuitable cleaning products

- Undiluted detergent
- Detergent intended for dishwashers
- Abrasive cleaners

- Aggressive cleaning products such as oven spray or stain remover
- Abrasive sponges
- High-pressure or steam jet cleaners

13.2 Cleaning the hob

Clean the hob after every use to stop cooking residues from getting burnt on.

Requirement: The hob must be cold. Do not allow the hob to cool down if it has sugar stains, rice starch, plastic or aluminium foil on it.

1. Remove heavy soiling using a glass scraper.
2. Clean the hob with a cleaning agent for glass ceramic.

Follow the cleaning instructions on the packaging of the cleaning agent.

Tips

- You can achieve good cleaning results using a special sponge for glass ceramic.
- If you keep the base of the cookware clean, the hob surface remains in a good condition.

13.3 Cleaning the control knob**Notes**

- Do not use a glass scraper.
 - You cannot remove the knob for cleaning.
 - Lemon and vinegar are not suitable for cleaning and may create dull patches.
1. Clean the control knob with warm soapy water and a soft cloth.
 2. Do not use too much water when cleaning.

13.4 Cleaning the hob surround

If the hob frame is dirty or stained after use, clean this.

Note: Do not use a glass scraper.

1. Clean the hob frame with hot soapy water and a soft cloth.
Wash new sponge cloths thoroughly before use.
2. Dry with a soft cloth.

13.5 Cleaning the connection strip**Notes**

- Do not use a glass scraper.
- Lemon and vinegar are not suitable for cleaning and may create dull patches.
- ▶ Clean the connection strip with warm soapy water and a soft cloth.

14 FAQs

This is where you can find an overview of the frequently asked questions regarding use, noises, cookware and cleaning.

14.1 Noises

Question	Answer
Why can I hear noises while I'm cooking?	<ul style="list-style-type: none"> ▪ Noises may be generated while using the hob depending on the base material of the cookware. These noises are normal for induction technology. They do not indicate that there is a fault.
What noises can occur and what is the significance of the noises?	<ul style="list-style-type: none"> ▪ A deep humming noise similar to a transformer: Occurs when cooking at a high power level. This noise disappears or becomes quieter when you reduce the power level. ▪ A quiet whistling noise: This can be heard when the cookware is empty. This noise disappears when you add water or food to the cookware. ▪ Crackling: This noise occurs when the cookware is made from different multilayer materials, or if you use cookware of different sizes and different materials. The loudness of the noise can vary depending on the quantity of food being cooked or the cooking method. ▪ Loud whistling noises: These may arise if you are operating two cooking zones at the same time and at the maximum power level. These whistling noises disappear or become quieter when you reduce the power level. ▪ Fan noises: The hob is equipped with a fan that switches on automatically at high temperatures. The fan may also continue to run after you have switched the hob off if the temperature measured is still too high.

14.2 Cookware

Question	Answer
Which cookware is suitable for the induction hob?	<ul style="list-style-type: none"> ▪ You can find more information on which items of cookware are compatible with induction cooking in . → <i>"Suitable cookware", Page 6</i>
Why is the cooking zone not heating up?	<ul style="list-style-type: none"> ▪ The cookware is on a different cooking zone to the one that has been switched on. Ensure that you have switched on the correct cooking zone for the cookware. ▪ The cookware is too small for the cooking zone that is switched on or it is not suitable for induction cooking. Ensure that the cookware is suitable for induction cooking and that it is placed on the cooking zone which best corresponds to its size. You can find more information about this under . → <i>"Suitable cookware", Page 6</i> → <i>"Flex Zone", Page 9</i>

Question	Answer
Why is it taking so long for the cookware to heat up or why is it not heating up sufficiently despite being on a high power setting?	<ul style="list-style-type: none"> ▪ The cookware is too small for the cooking zone that is switched on or it is not suitable for induction cooking. Ensure that the cookware is suitable for induction cooking and that it is placed on the cooking zone which best corresponds to its size. <p>You can find more information about this under .</p> <ul style="list-style-type: none"> → "Suitable cookware", Page 6 → "Flex Zone", Page 9

14.3 Cleaning

Question	Answer
How can I clean the hob?	<ul style="list-style-type: none"> ▪ You can achieve the best results by using special glass-ceramic cleaning products. Do not use harsh or abrasive cleaning products, dishwasher detergent (concentrated) or scouring pads. <p>You can find more information about this under .</p> <ul style="list-style-type: none"> → "Cleaning and servicing", Page 13

15 Troubleshooting

You can rectify minor faults on your appliance yourself. Read the troubleshooting information before contacting after-sales service. This will avoid unnecessary costs.

WARNING – Risk of injury!

Improper repairs are dangerous.

- ▶ Repairs to the appliance should only be carried out by trained specialist staff.
- ▶ If the appliance is defective, call Customer Service.
- "Customer Service", Page 16

WARNING – Risk of electric shock!

Improper repairs are dangerous.

- ▶ Repairs to the appliance should only be carried out by trained specialist staff.
- ▶ Only use genuine spare parts when repairing the appliance.
- ▶ If the power cord or the appliance power cable of this appliance is damaged, it must be replaced with a special power cord or special appliance power cable, which is available from the manufacturer or its Customer Service.
- ▶ If the power cord of this appliance is damaged, it must be replaced by trained specialist staff.

15.1 Malfunctions

Fault	Cause and troubleshooting
None	<p>There has been a power cut.</p> <ul style="list-style-type: none"> ▶ Check whether the lighting in your room or other appliances are working. <hr/> <p>The appliance has not been connected in accordance with the circuit diagram.</p> <ul style="list-style-type: none"> ▶ Ensure that the appliance has been connected as shown in the circuit diagram. → "Establishing the power supply", Page 21 <hr/> <p>The circuit breaker in the fuse box has tripped.</p> <ul style="list-style-type: none"> ▶ Check the circuit breaker in the fuse box. <hr/> <p>The electronics have detected a fault.</p> <ul style="list-style-type: none"> ▶ If this fault recurs, call the after-sales service.
The illuminated ring on the control knob flashes orange and white.	<p>The appliance has been operating continuously for an extended period. The safety shut-off has switched the heating process off.</p> <ol style="list-style-type: none"> 1. Turn the control knob to 0. 2. Switch the appliance back on. <hr/> <p>The control knob has not been turned for an extended period. The safety shut-off has switched the heating process off.</p> <ol style="list-style-type: none"> 1. Turn the control knob to 0. 2. Switch the appliance back on.

Fault	Cause and troubleshooting
The illuminated ring on the control knob flashes orange and white.	<p>The electronics have overheated and the affected cooking zone has been switched off.</p> <ol style="list-style-type: none"> 1. Wait until the electronics have cooled down sufficiently. 2. Switch on the cooking zone again.
Three signal tones sound. The illuminated ring on the control knob flashes three times.	<p>The electronics have overheated and all the cooking zones have been switched off.</p> <ol style="list-style-type: none"> 1. Wait until the electronics have cooled down sufficiently. 2. Switch on the cooking zone again. <p>The powerBoost function has not been activated correctly.</p> <ul style="list-style-type: none"> ▶ Activate the powerBoost → <i>Page 10</i> function. <p>The appliance has deactivated the powerBoost function to protect the electronic elements inside the hob.</p> <ol style="list-style-type: none"> 1. Turn the control knob to 0. 2. Switch the appliance back on.
The illuminated ring on the control knob flashes orange rapidly.	<p>The operating voltage is incorrect. The operating voltage is outside of the normal operating range.</p> <ul style="list-style-type: none"> ▶ Inform your electricity supplier. <p>The appliance has not been connected in accordance with the circuit diagram.</p> <ul style="list-style-type: none"> ▶ Ensure that the appliance has been connected in accordance with the circuit diagram. ▶ If this fault recurs immediately after switching back on, call our customer service.

15.2 If the error message is repeated, inform customer service

Requirement: The error message is not listed in the Overview → *Page 15*.

1. Disconnect the appliance from the mains power supply.
2. Wait 30 seconds.
3. Reconnect the appliance.
4. If the error message appears again, inform customer service and specify the exact error message.

15.3 Low power mode in the case of an error message

If the appliance displays an error message, the appliance does not switch to low power mode.

15.4 Deactivating demo mode

The appliance does not heat up in demo mode. If the illuminated ring on the control knob lights up white, demo mode is activated.

1. Disconnect the appliance from the mains power supply.
2. Wait at least 30 seconds.
3. Re-connect the appliance.
 - ▶ Deactivate demo mode within the next 3 minutes.
4. Turn the control knob one notch anti-clockwise to ».
5. Turn the same control knob three notches clockwise to Ⅴ.
6. Turn the same control knob two notches anti-clockwise to 0.
 - ✓ The illuminated ring on the control knob lights up white.
 - ✓ Demo mode is deactivated.

16 Customer Service

Function-relevant genuine spare parts according to the corresponding Ecodesign Order can be obtained from Customer Service for a period of at least 10 years from the date on which your appliance was placed on the market within the European Economic Area.

Note: Under the terms of the manufacturer's warranty the use of Customer Service is free of charge.

Detailed information about the warranty period and the warranty conditions in your country is available via the QR code on the enclosed document on service contacts and warranty conditions, from our customer service or on our website.

If you contact Customer Service, you will require the product number (E-Nr.) and the production number (FD) of your appliance.

You can find the contact details for our customer service via the QR code on the enclosed document on service contacts and warranty conditions or on our website. You can find the information required as per Regulations (EU) 66/2014 and (EU) 2023/826 online at www.gaggenau.com on the product and service pages for your appliance, in the area of user manuals and additional documents.

16.1 Product number (E-Nr.) and production number (FD)

You can find the product number (E-Nr.) and the production number (FD) on the appliance's rating plate. The rating plate is located on the underside of the appliance.

The product number (E no.) can also be found on the glass ceramic. You can also display the customer service index (KI) and the production number (FD) in the basic settings.

Make a note of your appliance's details and the Customer Service telephone number to find them again quickly.

17 Installation instructions

Observe this information when installing the appliance.



← mm →

17.1 Scope of delivery

After unpacking all parts, check for any damage in transit and completeness of the delivery.

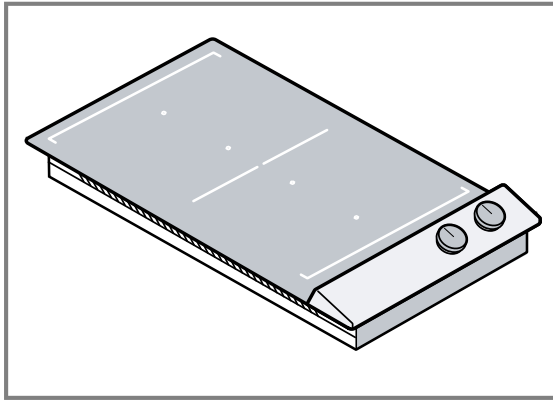

17.2 Appliance dimensions

You will find the dimensions of the appliance here

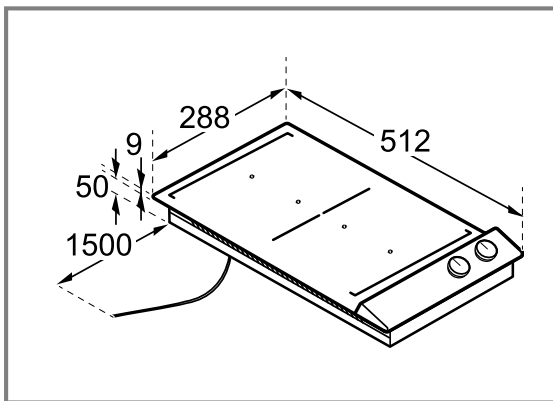

17.3 General information

- Read this instruction manual carefully.
- Only a licensed expert may connect the appliance.
- Switch off the power supply before carrying out any work.
- Never use this appliance in boats or in vehicles.
- Follow the worktop manufacturer's recommendations.

17.4 Safe installation

Follow these safety instructions when installing the appliance.

WARNING – Danger: Magnetism!

The appliance contains permanent magnets. These may affect electronic implants, e.g. heart pacemakers or insulin pumps.

- ▶ Persons with electronic implants must stay at least 10 cm away from the appliance.

WARNING – Risk of injury!

Components inside the appliance may have sharp edges.

- ▶ Wear protective gloves.

WARNING – Risk of electric shock!

Improper repairs are dangerous.

- ▶ Repairs to the appliance should only be carried out by trained specialist staff.
 - ▶ Only use genuine spare parts when repairing the appliance.
 - ▶ If the power cord or the appliance power cable of this appliance is damaged, it must be replaced with a special power cord or special appliance power cable, which is available from the manufacturer or its Customer Service.
 - ▶ If the power cord of this appliance is damaged, it must be replaced by trained specialist staff.
- Incorrect installation is dangerous.
- ▶ Connect and operate the appliance only in accordance with the specifications on the rating plate.
 - ▶ The protective conductor system of the domestic electrical installation must be properly installed.
 - ▶ Never equip the appliance with an external switching device, e.g. a timer or remote control.
 - ▶ When the appliance is installed, the mains plug of the power cord must be freely accessible. If free access is not possible, an isolating switch must be integrated into the permanent electrical installation according to the installation regulations.
 - ▶ When installing the appliance, check that the power cable is not trapped or damaged.

Only an appliance which has been correctly installed in accordance with these installation instructions can be used safely. The installer shall be liable for damages incurred as a result of incorrect installation.

17.5 Notes on the installation

Observe the following installation instructions.

- Improper installation, connection or incorrect installation may lead to loss of the warranty.
- You can only install the induction hob above drawers or ovens with fan ventilation.

- Do not install refrigerators, dishwashers, non-ventilated ovens or washing machines underneath the appliance.
- The clearance between the extractor hood and the hob must correspond at least to the clearance specified in the installation instructions for the extractor hood.
- The worktop must be level, horizontal and stable. Follow the instructions provided by the worktop manufacturer.
- If the thickness of the worktop does not comply with the specifications, reinforce the worktop using a fire- and water-resistant material until it reaches the minimum thickness. Otherwise, sufficient stability cannot be guaranteed.
- The worktop into which you install the hob should be able to withstand loads of approx. 60 kg. If necessary, strengthen the worktop with heat- and water-resistant material.
- Only check that the hob is level once it has been installed.

Installation above a drawer

The worktop must be at least 20 mm thick.

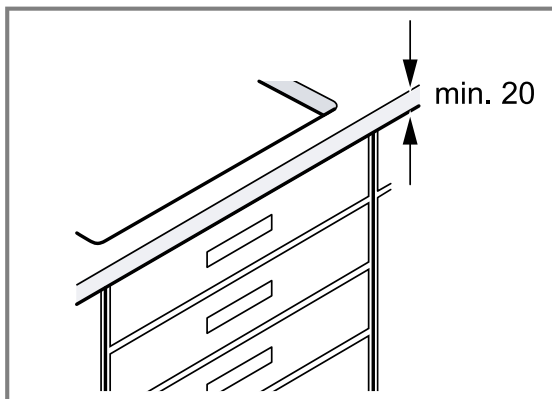

In order to guarantee good ventilation, the clearance between the surface of the worktop and the upper area of the drawer must be at least 65 mm.

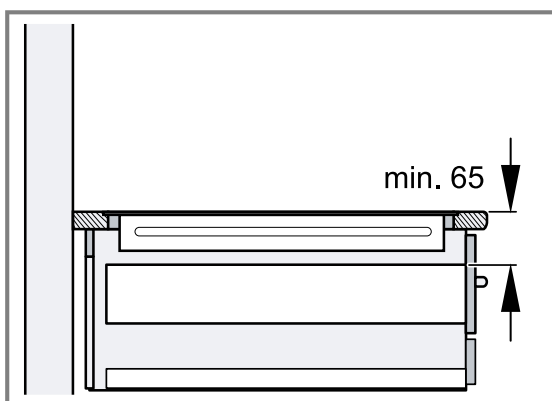

Note: Only use a wooden intermediate shelf if metal objects in the drawer reach high temperatures due to the recirculating air from the hob's ventilation.

Installation above an oven

The worktop must be at least 30 mm thick.

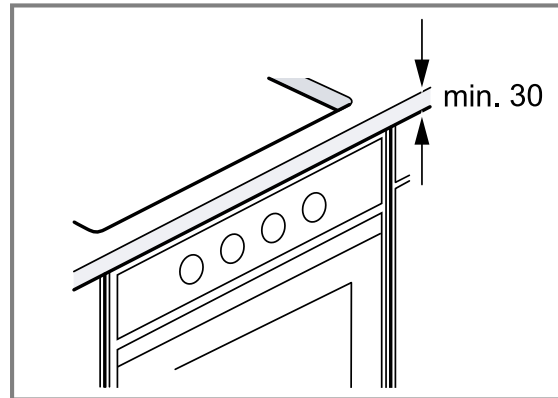

To ensure good ventilation, the distance between the oven and the hob must be at least 5 mm.

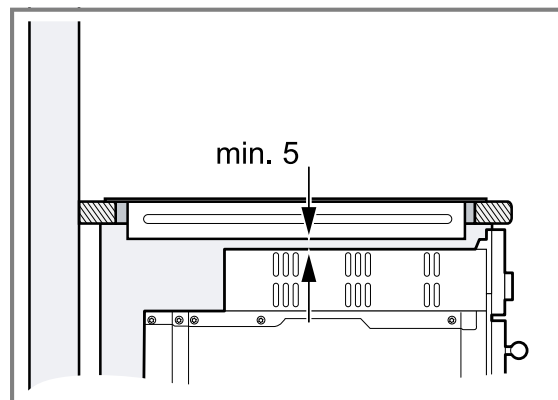

Notes

- If the clearance between the hob and the oven needs to be increased, refer to the installation instructions for the oven.
- If you install the hob above an oven made by another brand, use a wooden intermediate floor.

17.6 Instructions for the electrical connection

In order to safely connect the appliance to the electrical system, follow these instructions.

- Check the household wiring before connecting the appliance. Ensure that there is sufficient fuse protection for the household wiring. The voltage and frequency of the appliance must match the electrical wiring; see the rating plate.
- Ensure that the power supply is properly earthed, that the fuse protection is sufficient and the cable and wiring system in the building is sufficiently dimensioned for the electrical power of the appliance.
- Route the connection cable in such a way that it does not touch the hot casing.
- Use only the connection cable that is supplied with the appliance or is provided by technical customer service.
- This appliance complies with the EC interference suppression regulations.
- The appliance corresponds to protection class 1. You should therefore only use the appliance with a protective earth connection.

- Ensure that contact protection is guaranteed when the appliance is installed.
- Only a qualified electrician may connect appliances without a plug. They are subject to the requirements of the local electricity provider. We recommend installing a residual current circuit breaker (RCCB) in the appliance's power supply circuit.
- Carry out the electrical connection in accordance with the installation instructions. The appliance may be damaged if it is not connected correctly.
- The manufacturer accepts no liability for malfunctions or possible damage resulting from incorrect electrical wiring.

Connecting cable

The connection cable is connected to the mains socket for the hob or is included with the appliance.

- You can find the required connection data on the rating plate and in the connection diagram.
- Use only the connection cable that is supplied with the appliance or is provided by customer service. If you require a longer cable, contact customer service. The maximum length of the connection cable is 2.20 m.

17.7 Combining multiple appliances

Requirement: You need a suitable connection strip to combine several Vario appliances. You can obtain the connection strip as an optional accessory.

1. When making the unit cut-out, allow extra space for the connecting strip between the appliances.
 - ▶ Observe the installation instructions for the connection strip.

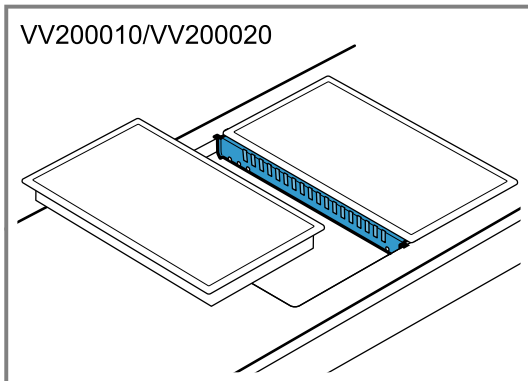

2. If required, install the appliances in individual cut-outs.
 - ▶ Maintain a bar width of at least 40 mm between the individual cut-outs.

17.8 Installation accessories

Here, you can find an overview of the installation accessories.

Use the accessories only as specified. The manufacturer shall accept no liability if you use the accessories incorrectly.

Accessories	Order number
Appliance cover, black	VD200020
Connecting strip, stainless steel	VV200010
Connecting strip, black	VV200020

17.9 Preparing the unit

ATTENTION

A fan is located on the underside of this hob.

- ▶ If a drawer is located on the underside of the hob, do not store any small or pointed objects, paper or tea towels in it. These objects may be sucked in and damage the fan or impair the cooling.
- ▶ There must be a clearance of at least 2 cm between the contents of the drawer and the fan entry point.

Requirements

- The fitted units are heat-resistant up to 90 °C.
 - The worktop is level, horizontal and stable.
1. Follow the instructions on combining several appliances.
 - "Combining multiple appliances", Page 19
 2. Ensure that the thickness of the worktop corresponds to the required minimum thickness.

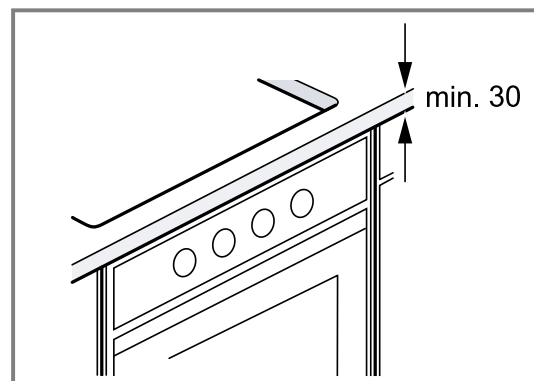
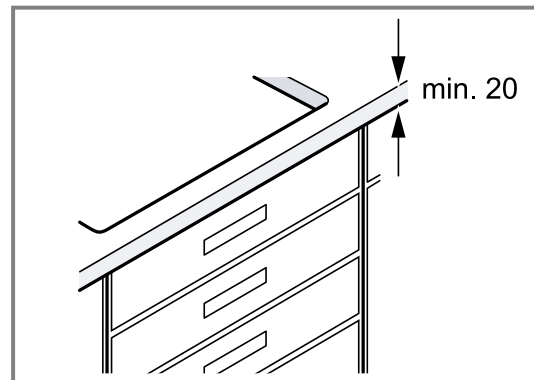

3. Maintain the minimum clearance from the upper edge of the worktop to the upper edge of a drawer installed below it.

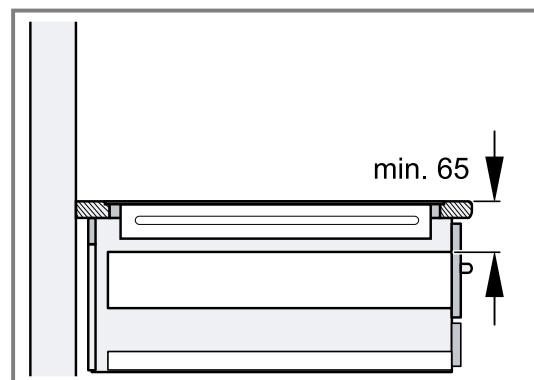

4. Mark the unit cut-out in accordance with the installation diagram.

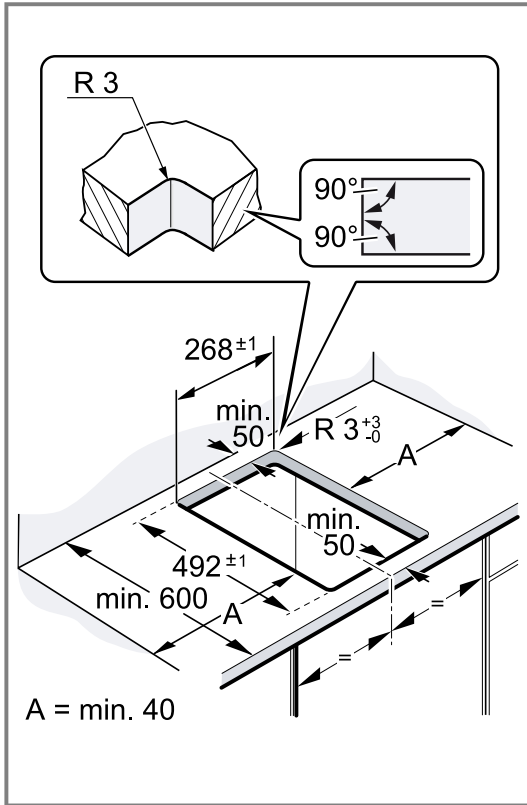

5. Ensure that the angle of the cut surface to the worktop is 90°.

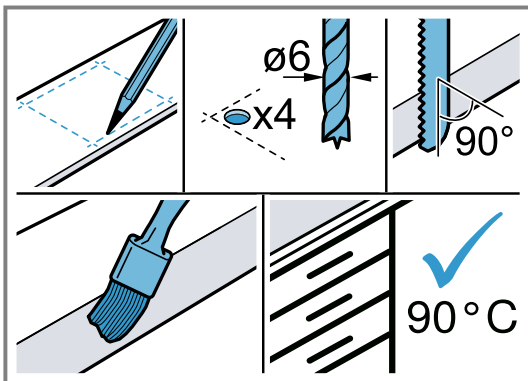

6. Remove dust and residues from the cut-out work. Seal the cut surfaces so that they are heat-resistant and waterproof.
7. Provide an intermediate floor between the appliance and the top drawer.

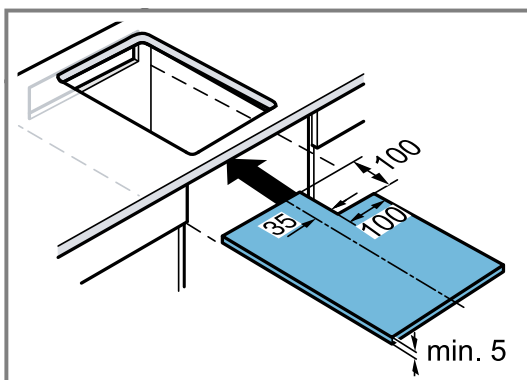

8. Observe the clearance between the intermediate floor and the worktop.

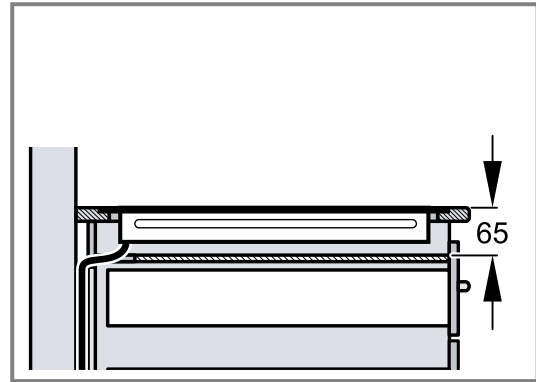

Creating ventilation openings

Requirement: The appliance requires sufficient ventilation from below to function correctly.

1. Make a unit cut-out in the upper area on the rear of the unit.

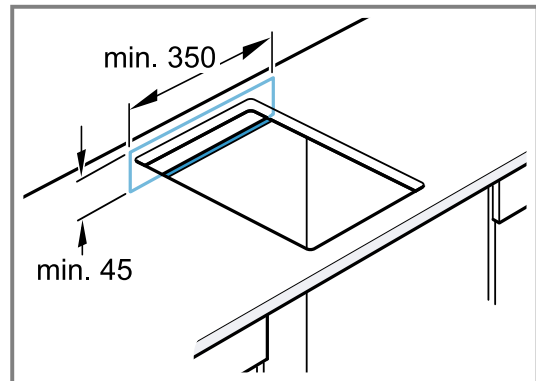

2. Observe the minimum clearances.

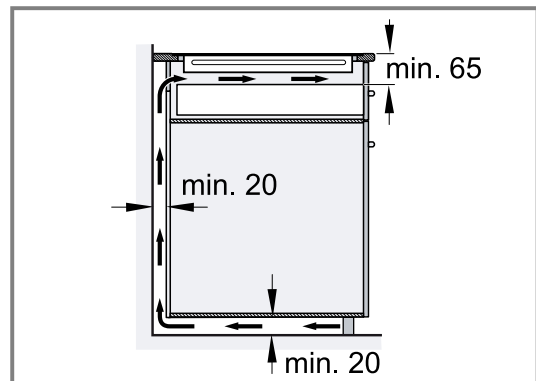

3. If there is no minimum clearance at the rear of the unit, make a unit cut-out in the bottom of the unit.

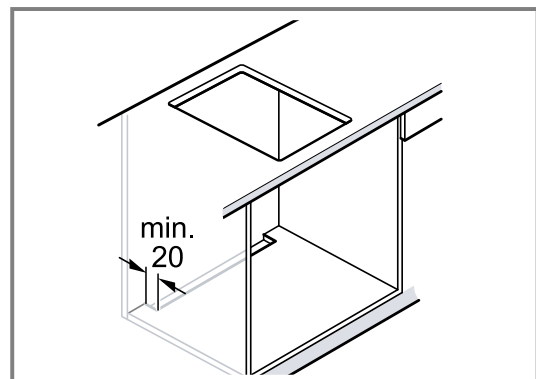

4. Ensure that the base of the unit is sufficiently ventilated.
5. When installing in a cooking island, ensure that the appliance is well ventilated.

17.10 Installing the appliance

⚠ WARNING – Risk of electric shock!

If the insulation of the power cord is damaged, this is dangerous.

- ▶ Never let the power cord come into contact with hot appliance parts or heat sources.
- ▶ Never let the power cord come into contact with sharp points or edges.
- ▶ Never kink, crush or modify the power cord.

1. Keeping the appliance level, insert it into the unit cut-out.

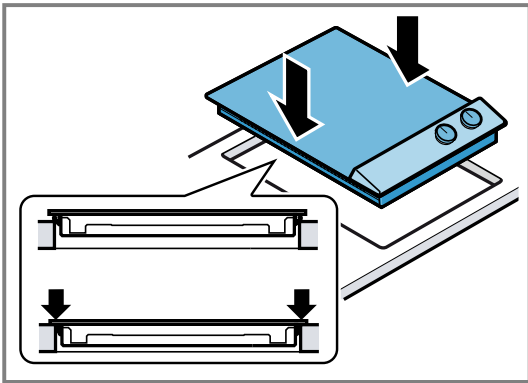

2. If the oven is a built-under type, route the mains connection cable along the rear corners of the oven to the mains socket.

17.11 Establishing the power supply

1. Observe the connection data on the rating plate.
2. Connect the cable to the mains socket in accordance with the figure.

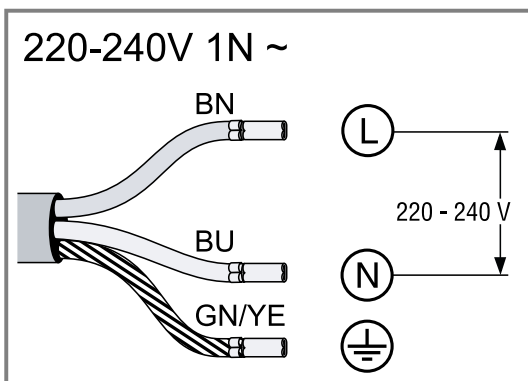

3. Note the colours of the cables.
 - BN: Brown
 - BU: Blue
 - GN/YE: Green and yellow

17.12 Checking the functionality

1. Switch on the appliance.
2. Use the operating instructions to check that the appliance is working.

17.13 Removing the appliance

⚠ WARNING – Risk of electric shock!

When disconnecting the appliance from the power supply, the terminals may cause reverse voltage.

- ▶ The electrical connection must only be carried out by licensed specialist staff.

ATTENTION

Tools may damage the appliance frame.

- ▶ Do not prise out the appliance from above.

1. Disconnect the appliance from the power supply.
2. Push out the appliance from below.



A series of horizontal lines spanning the width of the page, providing a template for writing.

The difference is Gaggenau

gaggenau.com

BSH Hausgeräte GmbH
Carl-Wery-Straße 34
81739 München, GERMANY
www.gaggenau.com

Valid within Great Britain:
Imported to Great Britain by
BSH Home Appliances Ltd.
Grand Union House
Old Wolverton Road
Wolverton, Milton Keynes
MK12 5PT
United Kingdom



9001867958 (050409) REG25
en